

UA9
Interface transducer for
phase cut signals



UA9

Technical data

Supply voltage	AC 24 V +15/-10 %
Control input:	
Range	DC 0 ... 10 V
Impedance	100 kΩ
Slave input:	
Range	DC 0 ... 20 V phase cut
Impedance	3 kΩ, electrically isolated
Output "Y"	DC 0 ... 20 V phase cut, max 40 W
"C+"	DC 20 V max 40 W
Electrical connection	
Two-part plug-in screw terminals	9 x 2.5 mm ²
Protection class	III (⊕)
Protection standard	IP20 to IEC529
Ambient temperature:	
Operation	0 ... 45 °C
Storage	-25 ... 70 °C
Weight including packaging	0.2 kg

Important notes:

The transformer power must be appropriate for the valve load (approx. 1.5 times the magnet power).

Principle of operation

The DC 0 ... 10 V control signal (at terminals 3 and 4) is electrically isolated in a high impedance input-differential amplifier, and converted into a proportional phase-cut signal of DC 0 ... 20 V. The supply voltage are regulated by the electronic circuit, thereby extending the service life of the valve.

A DC 0 ... 20 V phase cut signal can be connected to the slave input (terminals 5 and 6). This input signal is electrically isolated with an AC opto-isolator and transmitted to the output stage without amplification or attenuation. When operating in this mode, the UA9 must be from the same supply as the supply to the master signal controller (device).

The signal at output "C-" can be used for an override circuit.

Electrical protection

The control inputs are proof against interference voltages up to AC / DC 50 V.

The phase cut output signal is sustained short circuit proof (max. 5 A for 1 ms per mains cycle).

A PTC resistor (3 A) protects output "C-" (terminal 7) against short circuits.

Dimensions [mm]

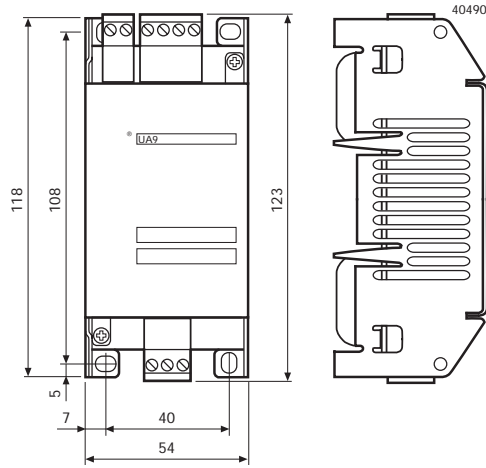

Block diagram

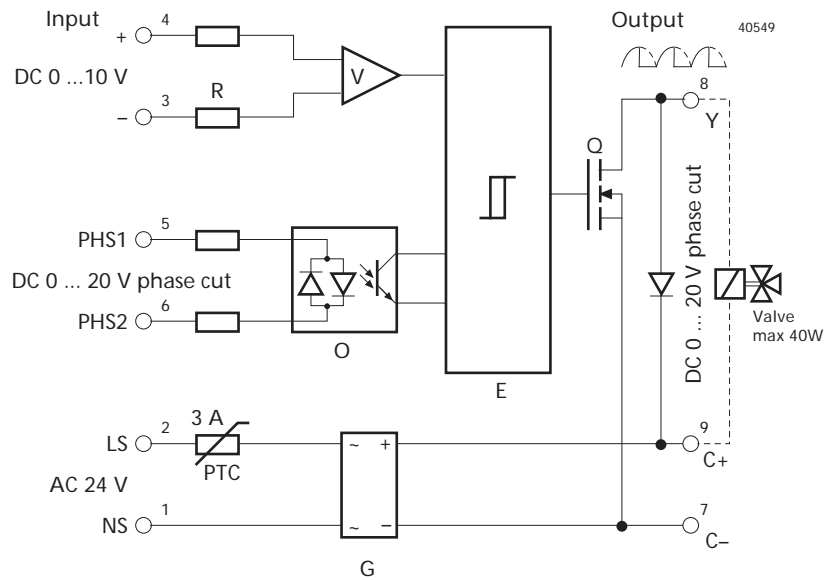

- R 100 kΩ input resistors
- E Electronic phase cut conditioning
- O Opto-isolator for electrical isolation of the slave input
- V High impedance differential amplifier for DC 0 ... 10 V control input
- G Bridge rectifier
- Q Phase cut output stage

Terminal layout

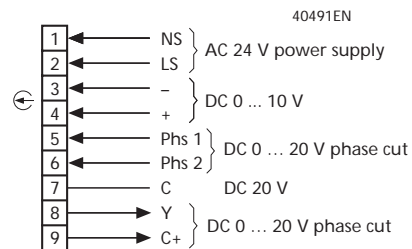

Important:

The supply to the UA9, when used as a slave device, must be on the same phase as the supply to the master signal controller (device).

Connection examples

1. Connection to controllers with 4-wire connections

e.g. INTEGRAL RSA, RSC, RSM, MULTIREG, and other controllers.
Power supply from controller transformer or separate transformer.

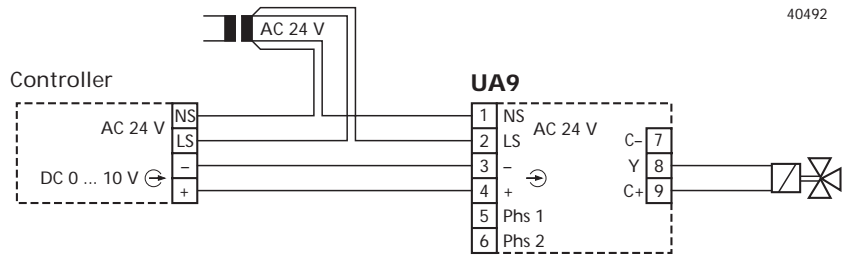

2. Connection to controllers with 3-wire connections

e.g. CLASSIC or other controllers.
Power supply from controller transformer or separate transformer.

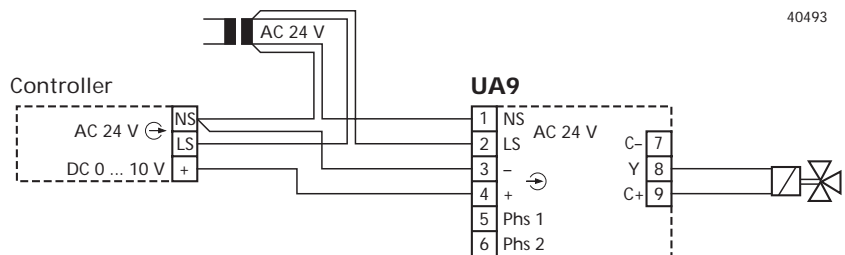

3. Operation as a slave amplifier

Power supply from controller transformer or separate transformer.
Master signal DC 0 ... 20 V phase cut.

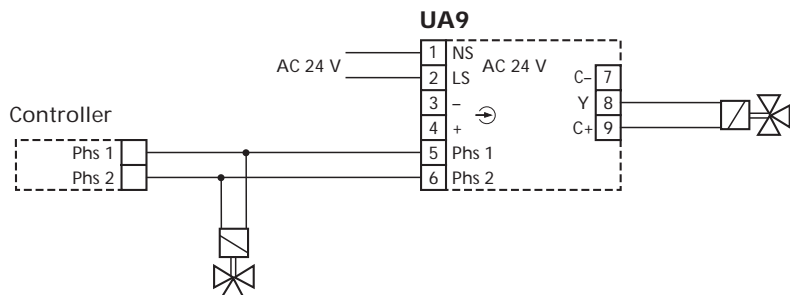

Important:

The supply to the UA9, when used as a slave device, must be on the same phase as the supply to the master signal controller (device).

Note: Several UA9 transducers may be connected to the same master signal (for synchronous operation of a number of valves).

4. Auto - On - Off override control

V = Recommended contact protection (47V VDR / ZNR resistor)

